

## Combi-Cabinets - Overview

### The Multifunctional

Two in one - central and safe.

#### Everything safe at access.

The combined cabinets offer the possibility to store hazardous materials and acids and alkalis without violating the rules of segregation.

The flexible interior equipment versions provide optimal customisation for all materials that have to be stored.

**TYPE 90** EN 14470-1  
Fire resistance  
**90 minutes**  
FIRE CHAMBER TESTED - TYPE PROVED  
(Compartment VBFT)

Approved storage of hazardous materials in workrooms in accordance with EN 14470-1 (Type 90) and other chemicals (acids and alkalis)



Model VBFT.SL+  
VBFT with 6 drawers / SL with 6 pull-out shelves incl. PP tray



Model VBFT.SL+  
VBFT with 4 shelves / SL with 4 pull-out shelves incl. PP tray

RAL 7035

EN  CE



Type tested according to EN 14470-1 (Type 90).  
(Compartment VBFT).

## Combi-Cabinets - A technology which sets new standards

### Combi-Cabinet for flammable liquids, acids and alkalis

- Complete fire resistant construction of the cabinet exterior
- Compartment VBFT: 90 min. fire resistant in accordance with **EN 14470-1 (Type 90)**
- Fire resistant middle wall inside
- 1 central extraction air inlet on the top
- Adjusting aids to compensate for uneven floor
- Earthing link (standard)

### Cabinet with folding door VBFT

TSA = automatic-door-closing system

#### High convenience and safety

- Integrated door open arrest system - **the arrested doors enable you to safely store or remove containers in the cabinet**
- Closing element with negative spring, **almost effortless (approx. 10 Newton) when opening**; high force during automatic closing procedure - **the doors are pulled safely and tightly into the cabinet frame and the sealing elements**
- Time-controlled pulse generator - **the doors close automatically after approx. 60 seconds after the cabinet has been opened (adjustable)**
- Pneumatic damping unit - **consistent smooth and quiet closure of the doors**

- The closing of the doors can be stopped at any time - **simply arrest the doors again with the door open arrest system by using one hand**; the mechanically controlled pulse generator is activated again
- **It is possible to close the doors manually (by hand) at any time!**
- Full covering anti-trapping door strip - maximum protection from injuries!

#### Standard configuration

- Door closing system outside the storage compartment: increased protection of moving and safety relevant components against corrosion
- Locking mechanism with cylinder lock (suitable for master-key systems)
- Extraction air inlet on top of the cabinet
- Integrated adjusting aids to compensate for uneven floor
- Earthing link

#### Safety in the event of a fire

- Fire resistance 90 minutes (type tested according to EN 14470-1, Type 90)
- Integrated thermal release systems, automatic closing of the doors and drawers

#### Large variety

- Either with shelves or drawers
- Optimal solutions for different needs

### Cabinet for acids and alkalis - SL

- Interior made from melamine for high chemical resistance
- Corrosion resistant air duct, non-metallic
- Two hermetically separated storage compartments
- Pull-out shelves with removable PP tray with high chemical resistance
- Capacity: 15 ltr.



**Drawers for storage** inside the fire resistant folding door cabinet. Safe and convenient storage and removal of small containers.



**Pull-out shelves** in the cabinet for acids and alkalis. Sturdy construction with removable PP trays.

## Combi-Cabinets



**Model VBFT.SL+**  
VBFT with 5 drawers / SL with 6 pull-out shelves  
incl. PP trays



**Model VBFT.SL+**  
VBFT with 4 drawers / SL with 4 pull-out shelves  
incl. PP trays

**Compartment VBFT**  
Door open arrest system  
+  
TSA - Automatic door closing system  
➔ fitted as standard

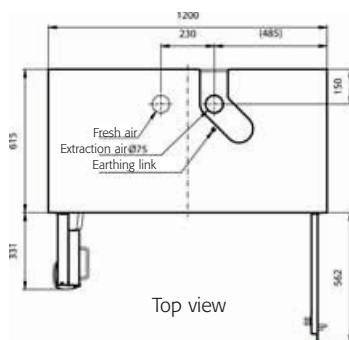

### Ventilation

Connection	mm	75
Change of air 30 times	m <sup>3</sup> /h	35
Pressure drop	Pa	45

## VBFT.SL+

### Approved storage of hazardous materials in workrooms

- Type tested in accordance with EN 14470-1 (90 minutes fire rated - Type 90)
- GS and CE conformity

### Technical data at a glance:

#### Cabinet

Dimensions W x D x H (mm):  
**exterior approx. 1200 x 615 x 1968**  
(height with base approx. 2090 mm)  
**interior approx. 1050 x 520 x 1740**  
Weight: **approx. 420 kg**  
Labelling in accordance with EN 14470-1

#### Drawers (compartment VBFT)

Load capacity (evenly distributed):  
Storage: **25 kg**, for used containers: **50 kg**  
Drawer dimensions W x D x H (mm):  
Storage: **approx. 345 x 500 x 50**  
Capacity: **approx. 5 ltr.**  
Disposal: **approx. 330 x 465 x 200**  
Capacity: **approx. 29 ltr.**

#### Storage capacity for each drawer/container

(please note the height of the containers)

Quantity	Type of container	Volume
<b>12</b>	lab bottle (glass)	1 litre
<b>12</b>	lab bottle (PE)	1 litre
<b>6</b>	lab bottle (glass)	2,5 litres

#### Pull-out shelves (compartment SL)

Load capacity (evenly distributed): **25 kg**  
Drawer dimensions W x D x H (mm):  
**approx. 430 x 475 x 80**  
Capacity: **approx. 15 ltr.**

#### Storage capacity for each drawer/container

(please note the height of the containers)

Quantity	Type of container	Volume
<b>16</b>	lab bottle (glass)	1 litre
<b>16</b>	lab bottle (PE)	1 litre
<b>8</b>	lab bottle (glass)	2,5 litres

### Combi-Cabinets with folding and wing door

Model	Material, colour	recommended quantity	Order Code
VBFT.SL+, Combi-Cabinet excl. interior equipment	light grey, RAL 7035		<b>21230</b>
<b>Interior equipment (drawers), compartment VBFT</b>			
4 drawers	sheet-steel, plastic laminated		<b>4 x 23224</b>
6 drawers	sheet-steel, plastic laminated		<b>6 x 23224</b>
<b>Interior equipment (pull-out shelves), compartment SL</b>			
4 pull-out shelves	incl. PP trays		<b>18412</b>
6 pull-out shelves	incl. PP trays		<b>18409</b>

Interior equipment (Compartment VBFT) in stainless steel and further drawer combinations available upon request.

## Combi-Cabinets



**Model VBFT.SL+**  
VBFT with 4 shelves / SL with 6 pull-out shelves  
incl. PP trays



**Model VBFT.SL+**  
VBFT with 4 shelves / SL with 4 pull-out shelves  
incl. PP trays

## VBFT.SL+

### Approved storage of hazardous materials in workrooms

- Type tested in accordance with EN 14470-1 (90 minutes fire rated - Type 90)
- GS and CE conformity

### Technical data at a glance:

#### Cabinet

Dimensions W x D x H (mm):

**exterior approx. 1200 x 615 x 1968**  
(height with base approx. 2090 mm)

**interior approx. 1050 x 520 x 1740**

Weight: **approx. 420 kg**

Labelling in accordance with EN 14470-1

#### Shelves (compartment VBFT)

Height adjustable (32 mm increments)

Load capacity (evenly distributed): **75 kg**

Dimensions W x D x H (mm):

**approx. 443 x 435 x 30**

Capacity of the bottom collecting sump:

**approx. 22 ltr.**

#### Pull-out shelves (compartment SL)

Load capacity (evenly distributed): **25 kg**

Drawer dimensions W x D x H (mm):

**approx. 430 x 475 x 80**

Capacity: **approx. 15 ltr.**

#### Storage capacity for each drawer/container

(please note the height of the containers)

Quantity	Type of container	Volume
<b>16</b>	lab bottle (glass)	1 litre
<b>16</b>	lab bottle (PE)	1 litre
<b>8</b>	lab bottle (glass)	2,5 litres

### Compartment VBFT

Door open arrest system

+

TSA - Automatic door closing system

➔ fitted as standard

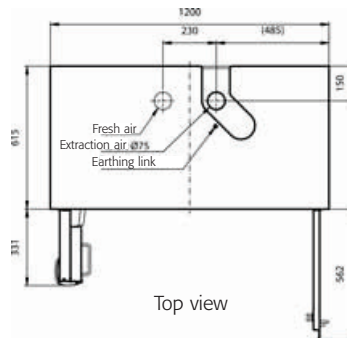

Top view

### Ventilation

Connection	mm	75
Change of air 30 times	m <sup>3</sup> /h	35
Pressure drop	Pa	45

### Combi-Cabinets with folding and wing door

Model	Material, colour	recommended quantity	Order Code
VBFT.SL+, Combi-Cabinet excl. interior equipment	light grey, RAL 7035		<b>21230</b>
<b>Interior equipment (shelves), compartment VBFT</b>			
Bottom collecting sump (V=22 ltr.)	sheet-steel, plastic laminated	1	<b>7455</b>
Perforated metal plate insert	sheet-steel, plastic laminated	1	<b>5555</b>
Shelf	sheet-steel, plastic laminated	3	<b>5553</b>
<b>Interior equipment (pull-out shelves), compartment SL</b>			
4 pull-out shelves	incl. PP trays		<b>18412</b>
6 pull-out shelves	incl. PP trays		<b>18409</b>

Interior equipment (Compartment VBFT) in stainless steel and further drawer combinations available upon request.