

«« Safety Storage Cabinets

PHOENIX Vol. 2 Safety storage cabinets with folding doors - Overview

Ingeniously simple - simply ingenious
 Convenient and efficient.

- AGT - Open two doors with one grip of the hand - almost effortless
- + TSA - Automatic door closing system!
- = Safe and user-friendly

TYPE 90 EN 14470-1
 Fire resistance
90 minutes
 FIRE CHAMBER TESTED - TYPE PROVED

Approved storage of hazardous materials in workrooms in accordance with EN 14470-1 (Type 90)



PHOENIX Vol.2 Model VBFT196.120+ with drawers (page 30)



PHOENIX Vol.2 Model VBFT196.120-G+ with shelves (page 30)



PHOENIX Vol.2 Model VBFT196.120-M+ with shelves or drawers (page 31)



PHOENIX Vol.2 Model VBFT196.60-G+ with shelves (page 32)



PHOENIX Vol.2 Model VBFT196.6.7+ special depth 750 mm with drawers (page 33)

RAL 1004 RAL 7035

EN CE

with restrictions



Type tested according to EN 14470-1 (Type 90).

PHOENIX Vol. 2 A technology which sets new standards

The new folding door cabinet PHOENIX Vol. 2 - ergonomic and safe

AGT = one hand opening mechanism

- easy and safe operating of the cabinet, even while holding a container in your hand
- Opening of two doors with just one grip

TSA = automatic door closing system

High convenience and safety

- Integrated door open arrest system - **the arrested doors enable you to safely store or remove containers in the cabinet**
- Closing element with negative spring - **almost effortless (approx. 10 Newton) opening**; high force during automatic closing procedure; **the doors are pulled safely and tightly**

into the cabinet frame and the sealing elements

- Time-controlled pulse generator - **The doors close automatically after approx. 60 seconds after the cabinet has been opened (adjustable)**
- Pneumatic damping unit - **consistent smooth and quiet closure of the doors**
- The closing of the doors can be stopped at any time - **simply arrest the doors again with the door open arrest system by using one hand**; the pulse generator is activated again
- Full covering anti-trapping door strip - maximum protection from injuries!

Safety in the event of a fire

- Fire resistance 90 minutes (type tested)

according to EN 14470-1, Type 90)

- Integrated thermal release systems, automatic closing of the doors and drawers

Large variety

- Either with shelves or drawers
- Optimal solutions for different needs
- Storage capacity of up to 235 ltr. (6 large drawers with 1 ltr. and 2.5 ltr. laboratory bottles)



Pull the handle of the right door and as if by magic the left door will follow automatically without being touched due to an **asynchronous coupled door opening mechanism**.

Almost effortlessly you can **arrest both doors with the standard door open arrest system**, while holding the container safely in your hand.



The arrested doors enable you to safely store or remove containers.

Containers were stored or removed? Simply go back to your workplace, while the cabinet will do the rest.

Approx. 60 seconds after the cabinet has been opened the arrested doors will be released due to the **integrated automatic door closing system** and will close completely.

«« Safety Storage Cabinets

PHOENIX Vol. 2 Type 90 Safety storage cabinets with folding doors



PHOENIX Vol.2 Model VBFT196.120+ with drawers



PHOENIX Vol.2 Model VBFT196.120-G+ with shelves

AGT - Open two doors with one grip of the hand - almost effortless
+ TSA - Automatic door closing system
➔ fitted as standard

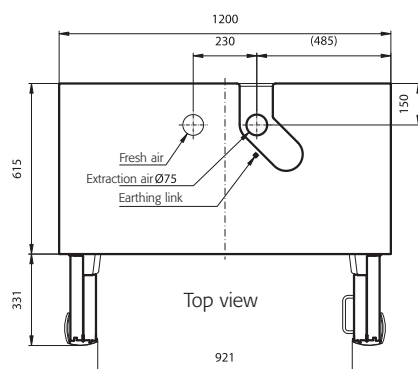

VBFT196.120+

Approved storage of hazardous materials in workrooms

- Type tested in accordance with EN 14470-1 (**90 minutes fire rated - Type 90**)
- GS and CE conformity

Technical data at a glance:

Cabinet

Dimensions W x D x H (mm):

exterior approx. 1200 x 615 x 1968

(height with base approx. 2090 mm)

interior approx. 1050 x 520 x 1740

Weight: **approx. 420 kg**

Labelling in accordance with EN 14470-1

Drawers

Load capacity (evenly distributed): **60 kg**

Drawer dimensions W x D x H (mm):

approx. 840 x 490 x 90

Capacity: **approx. 29 ltr.**

Storage capacity for each drawer/container

(please note the height of the containers)

Quantity	Type of container	Volume
90	aerosol can	400 ml
40	steel tin	1 litre
40	lab bottle (glass)	1 litre
40	lab bottle (PE)	1 litre
15	lab bottle (glass)	2,5 litres

Shelves

Height adjustable (32 mm increments)

Load capacity (evenly distributed): **75 kg**

Dimensions W x D x H (mm):

approx. 1043 x 435 x 30

Capacity of the bottom

collecting sump: **approx. 33 ltr.**

Ventilation

Connection	mm	75
Change of air 10 times	m ³ /h	9
Pressure drop	Pa	4

Type 90 PHOENIX Vol.2 Safety storage cabinets with folding doors

Model	Material, colour	recommended quantity	Order Code
VBFT196.120+ , 2 folding doors, excl. interior equipment	light grey, RAL 7035		21239
VBFT196.120-G+ , 2 folding doors, excl. interior equipment	warning yellow, RAL 1004		21242
Interior equipment (shelves)			
Bottom collecting sump (V=33 ltr.)	sheet-steel, plastic laminated	1	5535
Perforated insert	sheet-steel, plastic laminated	1	5536
Shelf	sheet-steel, plastic laminated	3	5534
Interior equipment (drawers)			
4 drawers	sheet-steel, plastic laminated		4 x 23322
6 drawers	sheet-steel, plastic laminated		6 x 23322

Interior equipment in stainless steel and further drawer combinations available upon request.

PHOENIX Vol. 2 Type 90 Safety storage cabinets with folding doors



PHOENIX Vol.2 Model VBFT196.120-MG+ with middle wall, shelves and drawers



PHOENIX Vol.2 Model VBFT196.120-M+ with middle wall and drawers

TSA - Automatic door closing system
+
Door open arrest system
➔ fitted as standard

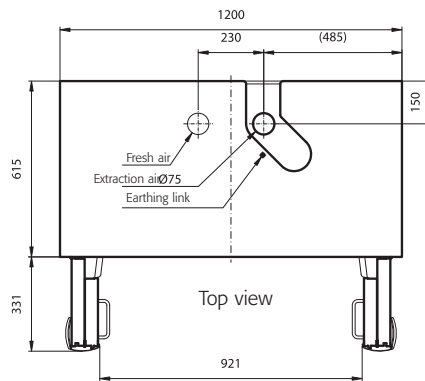

VBFT196.120-M+

Approved storage of hazardous materials in workrooms

- Type tested in accordance with EN 14470-1 (90 minutes fire rated - Type 90)
- GS and CE conformity

Technical data at a glance:

Cabinet

Dimensions W x D x H (mm):

exterior approx. 1200 x 615 x 1968
(height with base approx. 2090 mm)

interior approx. 1050 x 520 x 1740

Weight: **approx. 420 kg**

Labelling in accordance with EN 14470-1

Drawers

Load capacity (evenly distributed):

storage: **25 kg**, for used containers: **50 kg**

Drawer dimensions W x D x H (mm):

Storage: **approx. 345 x 500 x 50**

Capacity: **approx. 5 ltr.**

used containers: **approx. 330 x 465 x 200**

Capacity: **approx. 29 ltr.**

Storage capacity for each drawer/container

(please note the height of the containers)

Quantity	Type of container	Volume
30	aerosol can	400 ml
12	steel tin	1 litre
12	lab bottle (glass)	1 litre
12	lab bottle (PE)	1 litre
6	lab bottle (glass)	2,5 litres

Shelves

Height adjustable (32 mm increments)

Load capacity (evenly distributed): **75 kg**

Dimensions W x D x H (mm):

approx. 443 x 435 x 30

Capacity of the bottom

collecting sump: **approx. 22 ltr.**

Ventilation

Connection	mm	75
Change of air 10 times	m ³ /h	9
Pressure drop	Pa	4

Type 90 PHOENIX Vol.2 Safety storage cabinets with middle wall and folding doors

Model	Material, colour	recommended quantity	Order Code
VBFT196.120-M+, 2 folding doors, excl. interior equipment	light grey, RAL 7035		21248
VBFT196.120-MG+, 2 folding doors, excl. interior equipment	warning yellow, RAL 1004		21250
Interior equipment (shelves)			
Bottom collecting sump (V=22 ltr.)	sheet-steel, plastic laminated	1	7455
Perforated insert	sheet-steel, plastic laminated	1	5555
Shelf	sheet-steel, plastic laminated	3	5553
Interior equipment (drawers)			
4 drawers	sheet-steel, plastic laminated		4 x 23224
6 drawers	sheet-steel, plastic laminated		6 x 23224

Interior equipment in stainless steel and further drawer combinations available upon request.

«« Safety Storage Cabinets

PHOENIX Vol. 2 Type 90 Safety storage cabinets with folding door



PHOENIX Vol.2 Model VBFT196.60+ with drawers



PHOENIX Vol.2 Model VBFT196.60-G+ with shelves

VBFT196.60+

Approved storage of hazardous materials in workrooms

- Type tested in accordance with EN 14470-1 (90 minutes fire rated - Type 90)
- GS and CE conformity

Technical data at a glance:

Cabinet

Dimensions W x D x H (mm):

exterior approx. 600 x 615 x 1968

interior approx. 450 x 520 x 1740

Weight: **approx. 260 kg**

Labelling in accordance with EN 14470-1

Drawers

Load capacity (evenly distributed):

Storage: **25 kg**, for used containers: **50 kg**

Drawer dimensions W x D x H (mm):

Storage: **approx. 345 x 500 x 50**

Capacity: **approx. 5 ltr.**

Disposal: **approx. 330 x 465 x 200**

Capacity: **approx. 29 ltr.**

Storage capacity for each drawer/container

(please note the height of the containers)

Quantity	Type of container	Volume
30	aerosol can	400 ml
12	steel tin	1 litre
12	lab bottle (glass)	1 litre
12	lab bottle (PE)	1 litre
6	lab bottle (glass)	2,5 litres

Shelves

Height adjustable (32 mm increments)

Load capacity (evenly distributed): **75 kg**

Dimensions W x D x H (mm):

approx. 443 x 435 x 30

Capacity of the bottom

collecting sump: **approx. 22 ltr.**

TSA - Automatic door closing system

+

Door open arrest system

➔ **fitted as standard**

Ventilation

Connection	mm	75
Change of air 10 times	m ³ /h	4
Pressure drop	Pa	2

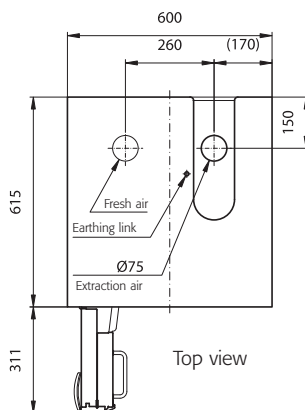

Type 90 PHOENIX Vol.2 Safety storage cabinets with folding door

Model	Material, colour	recommended quantity	Order No.
VBFT196.60+, 1 folding door, left hand, excl. interior equipment	light grey, RAL 7035		21278
VBFT196.60-R+, 1 folding door, right hand, excl. interior equipment	light grey, RAL 7035		21291
VBFT196.60-G+, 1 folding door, left hand, excl. interior equipment	warning yellow, RAL 1004		21283
VBFT196.60-GR+, 1 folding door, right hand, excl. interior equipment	warning yellow, RAL 1004		21285
Interior equipment (shelves)			
Bottom collecting sump (V=22 ltr.)	sheet-steel, plastic laminated	1	7455
Perforated insert	sheet-steel, plastic laminated	1	5555
Shelf	sheet-steel, plastic laminated	3	5553
Interior equipment (drawers)			
4 drawers	sheet-steel, plastic laminated		4 x 23224
6 drawers	sheet-steel, plastic laminated		6 x 23224

Interior equipment in stainless steel and further drawer combinations available upon request.

PHOENIX Vol. 2 Type 90 Safety storage cabinets with folding door



750 mm

PHOENIX Vol.2 Model VBFT196.6.7+ with drawers



750 mm

PHOENIX Vol.2 Model VBFT196.6.7+ with drawers

TSA - Automatic door closing system
+
Door open arrest system
➔ fitted as standard

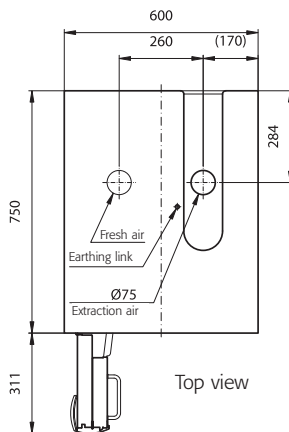

VBFT196.6.7+

Approved storage of hazardous materials in workrooms

- Type tested in accordance with EN 14470-1 (90 minutes fire rated - Type 90)
- GS and CE conformity

Technical data at a glance:

Cabinet

Dimensions W x D x H (mm):

exterior approx. 600 x 750 x 1968

interior approx. 450 x 655 x 1740

Weight: approx. 310 kg

Labelling in accordance with EN 14470-1

Drawers

Load capacity (evenly distributed):

Storage: 25 kg, for used containers: 50 kg

Drawer dimensions W x D x H (mm):

Storage: approx. 345 x 630 x 50

Capacity: approx. 6 ltr.

Disposal: approx. 330 x 600 x 160

Capacity: approx. 30 ltr.

Storage capacity for each drawer/container

(please note the height of the containers)

Quantity	Type of container	Volume
40	aerosol can	400 ml
17	steel tin	1 litre
17	lab bottle (glass)	1 litre
17	lab bottle (PE)	1 litre
8	lab bottle (glass)	2,5 litres

Ventilation

Connection	mm	75
Change of air 10 times	m ³ /h	5
Pressure drop	Pa	3

Type 90 PHOENIX Vol.2 Safety storage cabinets with folding door

Model	Material, colour	Interior equipment	Order Code
VBFT196.6.7+, 1 folding door, left hand, excl. interior equipment	light grey, RAL 7035		21258
VBFT196.6.7-R+, 1 folding door, right hand, excl. interior equipment	light grey, RAL 7035		21271
VBFT196.6.7-G+, 1 folding door, left hand, excl. interior equipment	warning yellow, RAL 1004		21263
VBFT196.6.7-GR+, 1 folding door, right hand, excl. interior equipment	warning yellow, RAL 1004		21265
Interior equipment (drawers)			
4 drawers	sheet-steel, plastic laminated		4 x 23254
6 drawers	sheet-steel, plastic laminated		6 x 23254

Interior equipment in stainless steel and further drawer combinations available upon request.