

«« Safety Storage Cabinets

PEGASUS Safety storage cabinets with wing doors - Overview

Ingeniously simple - simply ingenious
 Convenient and efficient.

- AGT - Open two doors with one grip of the hand - almost effortless**
- + TSA - Automatic door closing system**
- = Safe and user-friendly**



Approved storage of hazardous materials at the workplace in accordance with EN 14470-1 (Type 90)



PEGASUS Model VBF.196.120+
 Cabinet width 1200 mm with drawers or shelves (page 16)
 available also with middle wall (page 17)



PEGASUS Model VBF.196.90-G+
 Cabinet width 900 mm with drawers or shelves (page 18)



PEGASUS Model VBF.196.60-G+
 Cabinet width 600 mm with drawers or shelves (page 19)

RAL 1004 RAL 7035

EN CE



with restrictions



PEGASUS Model VBF.129.120-G+ (Height 1298 mm)
 Cabinet width 1200 mm with drawers or shelves (page 20)



PEGASUS Model VBF.129.60+ (Height 1298 mm)
 Cabinet width 600 mm with drawers or shelves (page 21)



Type tested according to EN 14470-1 (Type 90).

PEGASUS A technology which sets new standards

The new wing door cabinet PEGASUS - ergonomic and safe

AGT = one hand opening mechanism

- easy and safe operating of the cabinet, even while holding a container in your hand
- Opening of two doors with just one grip

TSA = automatic door closing system

High convenience and safety

- Integrated door open arrest system - **the arrested doors enable you to safely store or remove containers**
- Closing element with negative spring - **almost effortless (approx. 10 Newton) opening**; high force during automatic closing procedure; **the doors are pulled safely and tightly into the cabinet frame and the sealing elements**
- Time-controlled pulse generator -

The doors close automatically after approx. 60 seconds after the cabinet has been opened (adjustable)

- Pneumatic damping unit - **consistent smooth and quiet closure of the doors**
- The closing of the doors can be stopped at any time - **simply arrest the doors again with the door open arrest system by using one hand**; the pulse generator is activated again, **it is possible to close the doors manually (by hand) at any time!**

Safety in the event of a fire

- Fire resistance 90 minutes (type tested according to EN 14470-1, Type 90)
- Integrated thermal release systems, automatic closing of the doors and drawers

Large variety

- Either with shelves or drawers
- Optimal solutions for different needs
- Storage capacity of up to 235 ltr. (6 large drawers with 1 ltr. and 2.5 l laboratory bottles)



Pull the handle of the right door and as if by magic the left door will follow automatically without being touched due to an **asynchronous coupled door opening mechanism**.



Almost effortlessly you can arrest both doors with the **standard door open arrest system**, while holding the container safely in your hand.



The arrested doors enable you to safely store or remove containers.



Containers were stored or removed? Simply go back to your workplace, while the cabinet will do the rest.



Approx. 60 seconds after the cabinet has been opened the arrested doors will be released due to the **integrated automatic door closing system** and will close completely.

«« Safety Storage Cabinets

PEGASUS Type 90 Safety storage cabinets with wing doors



PEGASUS Model VBF.196.120-G+
with shelves



PEGASUS Model VBF.196.120+
with drawers

AGT - Open two doors with one grip of the hand - almost effortless
 +
TSA - Automatic door closing system
 +
Door open arrest system
 ➔ **fitted as standard**

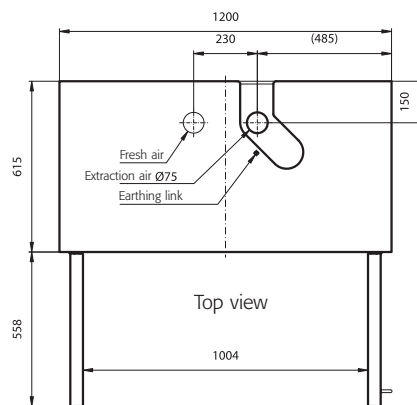

VBF.196.120+

Approved storage of hazardous materials in workrooms

- Type tested in accordance with EN 14470-1 (90 minutes fire rated - Type 90)
- GS and CE conformity

Technical data at a glance:

Cabinet

Dimensions W x D x H (mm):

exterior approx. 1200 x 615 x 1968
(height with base approx. 2090 mm)

interior approx. 1050 x 520 x 1740

Weight: **approx. 420 kg**

Labelling in accordance with EN 14470-1

Drawers

Load capacity (evenly distributed): **60 kg**

Drawer dimensions W x D x H (mm):

approx. 840 x 490 x 90

Capacity: **approx. 29 ltr.**

Storage capacity for each drawer/container (please note the height of the containers)

Quantity	Type of container	Volume
90	aerosol can	400 ml
40	steel tin	1 litre
40	lab bottle (glass)	1 litre
40	lab bottle (PE)	1 litre
15	lab bottle (glass)	2,5 litres

Shelves

Height adjustable (32 mm increments)

Load capacity (evenly distributed): **75 kg**

Dimensions W x D x H (mm):

approx. 1043 x 435 x 30

Capacity of the bottom

collecting sump: **approx. 33 ltr.**

Ventilation

Connection	mm	75
Change of air 10 times	m ³ /h	9
Pressure drop	Pa	4

Type 90 PEGASUS Safety storage cabinets with wing doors

Model	Material, colour	recommended quantity	Order Code
VBF.196.120+, 2 wing doors, excl. interior equipment	light grey, RAL 7035		20955
VBF.196.120-G+, 2 wing doors, excl. interior equipment	warning yellow, RAL 1004		20960
Interior equipment (shelves)			
Bottom collecting sump (V=33 ltr.)	sheet-steel, plastic laminated	1	5535
Perforated insert	sheet-steel, plastic laminated	1	5536
Shelf	sheet-steel, plastic laminated	3	5534
Interior equipment (drawers)			
4 drawers	sheet-steel, plastic laminated		4 x 23322
6 drawers	sheet-steel, plastic laminated		6 x 23322

Interior equipment in stainless steel and further drawer combinations available upon request.

PEGASUS Type 90 Safety storage cabinets with wing doors



PEGASUS Model VBF.196.120-MG+
with middle wall and shelves



PEGASUS Model VBF.196.120-M+
with middle wall and drawers

TSA - Automatic door closing system
+
Door open arrest system
➔ **fitted as standard**

Ventilation

Connection	mm	75
Change of air 10 times	m ³ /h	9
Pressure drop	Pa	4

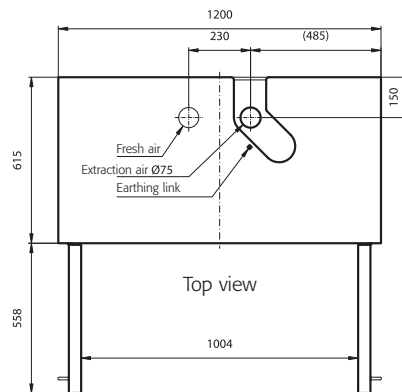

VBF.196.120-M+

Approved storage of hazardous materials in workrooms

- Type tested in accordance with EN 14470-1 (**90 minutes fire rated - Type 90**)
- GS and CE conformity

Technical data at a glance:

Cabinet

Dimensions W x D x H (mm):

exterior approx. 1200 x 615 x 1968

(height with base approx. 2090 mm)

interior approx. 2 x 450 x 520 x 1740

Weight: **approx. 420 kg**

Labelling in accordance with EN 14470-1

Drawers

Load capacity (evenly distributed):

storage: **25 kg**, for used containers: **50 kg**

Drawer dimensions W x D x H (mm):

Storage: **approx. 345 x 500 x 50**

Capacity: **approx. 5 ltr.**

Disposal: **approx. 330 x 465 x 200**

Capacity: **approx. 29 ltr.**

Storage capacity for each drawer/container

(please note the height of the containers)

Quantity	Type of container	Volume
30	aerosol can	400 ml
12	steel tin	1 litre
12	lab bottle (glass)	1 litre
12	lab bottle (PE)	1 litre
6	lab bottle (glass)	2,5 litres

Shelves

Height adjustable (32 mm increments)

Load capacity (evenly distributed): **75 kg**

Dimensions W x D x H (mm):

approx. 443 x 435 x 30

Collecting capacity of the bottom

collecting sump: **approx. 22 ltr.**

Type 90 PEGASUS Safety storage cabinets with wing doors with middle wall

Model	Material, colour	recommended quantity	Order Code
VBF.196.120-M+ , 2 wing doors, excl. interior equipment	light grey, RAL 7035		20962
VBF.196.120-MG+ , 2 wing doors, excl. interior equipment	warning yellow, RAL 1004		20964
Interior equipment (shelves)			
Bottom collecting sump (V=22 ltr.)	sheet-steel, plastic laminated	1	7455
Perforated insert	sheet-steel, plastic laminated	1	5555
Shelf	sheet-steel, plastic laminated	3	5553
Interior equipment (drawers)			
4 drawers	sheet-steel, plastic laminated		4 x 23224
6 drawers	sheet-steel, plastic laminated		6 x 23224

Interior equipment in stainless steel and further drawer combinations available upon request.

«« Safety Storage Cabinets

PEGASUS Type 90 Safety storage cabinets with wing doors



PEGASUS Model VBF.196.90+
with shelves



PEGASUS Model VBF.196.90-G+
with drawers

AGT - Open two doors with one grip of the hand - almost effortless
 +
TSA - Automatic door closing system
 +
Door open arrest system
 ➔ **fitted as standard**

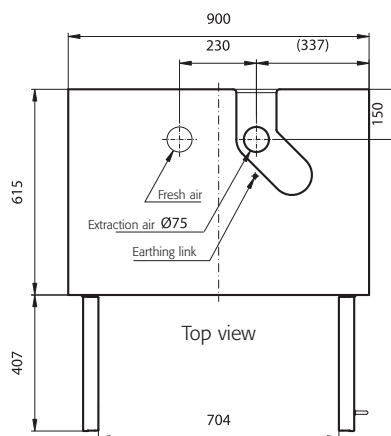

VBF.196.90+

Approved storage of hazardous materials in workrooms

- Type tested in accordance with EN 14470-1 (90 minutes fire rated - Type 90)
- GS and CE conformity

Technical data at a glance:

Cabinet

Dimensions W x D x H (mm):

exterior approx. 900 x 615 x 1968

interior approx. 750 x 520 x 1740

Weight: **approx. 310 kg**

Labelling in accordance with **EN 14470-1**

Drawers

Load capacity (evenly distributed): **60 kg**

Drawer dimensions W x D x H (mm):

approx. 540 x 490 x 90

Capacity: **approx. 19 ltr.**

Storage capacity for each drawer/container

(please note the height of the containers)

Quantity	Type of container	Volume
49	aerosol can	400 ml
23	steel tin	1 litre
23	lab bottle (glass)	1 litre
23	lab bottle (PE)	1 litre
9	lab bottle (glass)	2,5 litres

Shelves

Height adjustable (32 mm increments)

Load capacity (evenly distributed): **75 kg**

Dimensions W x D x H (mm):

approx. 743 x 435 x 30

Collecting capacity of the bottom collecting sump: **approx. 23 ltr.**

Ventilation

Connection	mm	75
Change of air 10 times	m ³ /h	6
Pressure drop	Pa	2

Type 90 PEGASUS Safety storage cabinets with wing doors

Model	Material, colour	recommended quantity	Order Code
VBF.196.90+, 2 wing doors, excl. interior equipment	light grey, RAL 7035		20988
VBF.196.90-G+, 2 wing doors, excl. interior equipment	warning yellow, RAL 1004		20991
Interior equipment (shelves)			
Bottom collecting sump (V=23 ltr.)	sheet-steel, plastic laminated	1	11164
Perforated insert	sheet-steel, plastic laminated	1	11165
Shelf	sheet-steel, plastic laminated	3	11166
Interior equipment (drawers)			
4 drawers	sheet-steel, plastic laminated		4 x 23332
6 drawers	sheet-steel, plastic laminated		6 x 23332

Interior equipment in stainless steel and further drawer combinations available upon request.

PEGASUS Type 90 Safety storage cabinets with wing door



PEGASUS Model VBF.196.60-G+
with shelves



PEGASUS Model VBF.196.60+
with drawers

TSA - Automatic door closing system
+
Door open arrest system
➔ **fitted as standard**

Ventilation

Connection	mm	75
Change of air 10 times	m ³ /h	4
Pressure drop	Pa	2

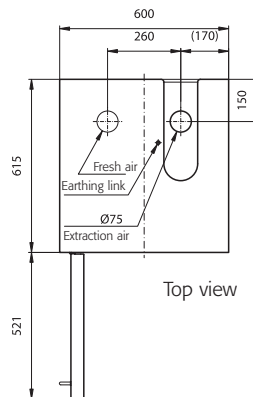

VBF.196.60+

Approved storage of hazardous materials in workrooms

- Type tested in accordance with EN 14470-1 (90 minutes fire rated - Type 90)
- GS and CE conformity

Technical data at a glance:

Cabinet

Dimensions W x D x H (mm):

exterior approx. 600 x 615 x 1968

interior approx. 450 x 520 x 1740

Weight: **approx. 260 kg**

Labelling in accordance with **EN 14470-1**

Drawers

Load capacity (evenly distributed):

storage: **25 kg**, for used containers: **50 kg**

Drawer dimensions W x D x H (mm):

Storage: **approx. 345 x 500 x 50**

Capacity: **approx. 5 ltr.**

Disposal: **approx. 330 x 465 x 200**

Capacity: **approx. 29 ltr.**

Storage capacity for each drawer/container

(please note the height of the containers)

Quantity	Type of container	Volume
30	aerosol can	400 ml
12	steel tin	1 litre
12	lab bottle (glass)	1 litre
12	lab bottle (PE)	1 litre
6	lab bottle (glass)	2,5 litres

Shelves

Height adjustable (32 mm increments)

Load capacity (evenly distributed): **75 kg**

Dimensions W x D x H (mm):

approx. 443 x 435 x 30

Collecting capacity of the bottom collecting sump: **approx. 22 ltr.**

Type 90 PEGASUS Safety storage cabinets with wing door

Model	Material, colour	recommended quantity	Order Code
VBF.196.60+, 1 wing door, left hand, excl. interior equipment	light grey, RAL 7035		20971
VBF.196.60-R+, 1 wing door, right hand, excl. interior equipment	light grey, RAL 7035		20983
VBF.196.60-G+, 1 wing door, left hand, excl. interior equipment	warning yellow, RAL 1004		20976
VBF.196.60-GR+, 1 wing door, right hand, excl. interior equipment	warning yellow, RAL 1004		20978
Interior equipment (shelves)			
Bottom collecting sump (V=22 ltr.)	sheet-steel, plastic laminated	1	7455
Perforated insert	sheet-steel, plastic laminated	1	5555
Shelf	sheet-steel, plastic laminated	3	5553
Interior equipment (drawers)			
4 drawers	sheet-steel, plastic laminated		4 x 23224
6 drawers	sheet-steel, plastic laminated		6 x 23224

Interior equipment in stainless steel and further drawer combinations available upon request.

«« Safety Storage Cabinets

PEGASUS Type 90 Safety storage cabinets with wing doors



PEGASUS Model VBF.129.120+
with shelves



PEGASUS Model VBF.129.120-G+
with drawers

AGT - Open two doors with one grip of the hand - almost effortless
 +
TSA - Automatic door closing system
 +
Door open arrest system
 ➔ **fitted as standard**

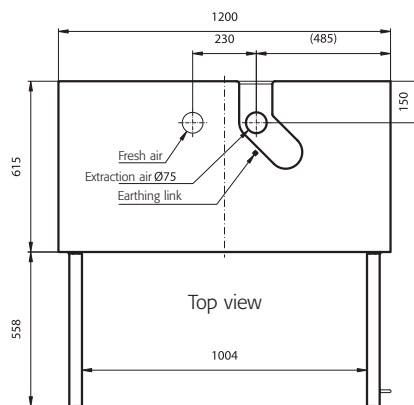

VBF.129.120+

Approved storage of hazardous materials in workrooms

- Type tested in accordance with EN 14470-1 (90 minutes fire rated - Type 90)
- GS and CE conformity

Technical data at a glance:

Cabinet

Dimensions W x D x H (mm):

exterior approx. 1200 x 615 x 1298

(height with base approx. 1420 mm)

interior approx. 1050 x 520 x 1070

Weight: **approx. 270 kg**

Labelling in accordance with EN 14470-1

Drawers

Load capacity (evenly distributed): **60 kg**

Drawer dimensions W x D x H (mm):

approx. 840 x 490 x 90

Capacity: **approx. 30 ltr.**

Storage capacity for each drawer/container

(please note the height of the containers)

Quantity	Type of container	Volume
90	aerosol can	400 ml
40	steel tin	1 litre
40	lab bottle (glass)	1 litre
40	lab bottle (PE)	1 litre
15	lab bottle (glass)	2,5 litres

Shelves

Height adjustable (32 mm increments)

Load capacity (evenly distributed): **75 kg**

Dimensions W x D x H (mm):

approx. 1043 x 435 x 30

Collecting capacity of the bottom collecting sump: **approx. 33 ltr.**

Ventilation

Connection	mm	75
Change of air 10 times	m ³ /h	5
Pressure drop	Pa	3

Type 90 PEGASUS Safety storage cabinets with wing doors

Model	Material, colour	recommended quantity	Order Code
VBF.129.120+, 2 wing doors, excl. interior equipment	light grey, RAL 7035		20909
VBF.129.120-G+, 2 wing doors, excl. interior equipment	warning yellow, RAL 1004		20912
Interior equipment (shelves)			
Bottom collecting sump (V=33 ltr.)	sheet-steel, plastic laminated	1	5535
Perforated insert	sheet-steel, plastic laminated	1	5536
Shelf	sheet-steel, plastic laminated	2	5534
Interior equipment (drawers)			
2 drawers	sheet-steel, plastic laminated		2 x 23322
3 drawers	sheet-steel, plastic laminated		3 x 23322

Interior equipment in stainless steel and further drawer combinations available upon request.

PEGASUS Type 90 Safety storage cabinets with wing door



PEGASUS Model VBF.129.60+
with shelves



PEGASUS Model VBF.129.60-G+
with drawers

TSA - Automatic door closing system
+
Door open arrest system
➔ **fitted as standard**

Ventilation

Connection	mm	75
Change of air 10 times	m ³ /h	4
Pressure drop	Pa	2

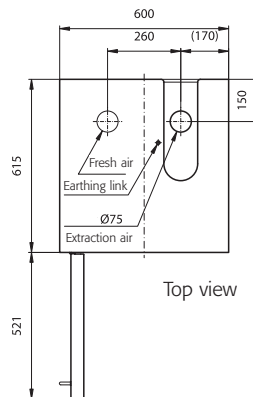

VBF.129.60+

Approved storage of hazardous materials in workrooms

- Type tested in accordance with EN 14470-1 (90 minutes fire rated - Type 90)
- GS and CE conformity

Technical data at a glance:

Cabinet

Dimensions W x D x H (mm):

exterior approx. 600 x 615 x 1298

interior approx. 450 x 520 x 1070

Weight: **approx. 170 kg**

Labelling in accordance with **EN 14470-1**

Drawers

Load capacity (evenly distributed): **25 kg**

Drawer dimensions W x D x H (mm):

approx. 345 x 500 x 50

Capacity: **approx. 5 ltr.**

Storage capacity for each drawer/container

(please note the height of the containers)

Quantity	Type of container	Volume
30	aerosol can	400 ml
12	steel tin	1 litre
12	lab bottle (glass)	1 litre
12	lab bottle (PE)	1 litre
6	lab bottle (glass)	2,5 litres

Shelves

Height adjustable (32 mm increments)

Load capacity (evenly distributed): **75 kg**

Dimensions W x D x H (mm):

approx. 443 x 435 x 30

Capacity of the bottom

collecting sump: **approx. 22 ltr.**

Type 90 PEGASUS Safety storage cabinets with wing door

Model	Material, colour	recommended quantity	Order Code
VBF.129.60+, 1 wing door, left hand, excl. interior equipment	light grey, RAL 7035		20914
VBF.129.60-R+, 1 wing door, right hand, excl. interior equipment	light grey, RAL 7035		20923
VBF.129.60-G+, 1 wing door, left hand, excl. interior equipment	warning yellow, RAL 1004		20919
VBF.129.60-GR+, 1 wing door, right hand, excl. interior equipment	warning yellow, RAL 1004		20921
Interior equipment (shelves)			
Bottom collecting sump (V=22 ltr.)	sheet-steel, plastic laminated	1	7455
Perforated insert	sheet-steel, plastic laminated	1	5555
Shelf	sheet-steel, plastic laminated	2	5553
Interior equipment (drawers)			
2 drawers	sheet-steel, plastic laminated		2 x 23224
3 drawers	sheet-steel, plastic laminated		3 x 23224

Interior equipment in stainless steel and further drawer combinations available upon request.